

# Footstep Voltage Generator using Piezo-Electric Transducers

Shrimoyee Poddar, Mohuya Dutta, Debashree Chowdhury, Abhinaba Dey, Debasis Maji

**Abstract**— In this project we are generating electrical power as non-conventional method by simply running on the train in the foot step. Non-conventional energy system is very essential at this time to our nation. Non-conventional energy using foot step needs no fuel input power to generate the output of the electrical power. This project uses simple drive mechanism.

**Index Terms**—Electrical Power, Piezo-electric Effect, Piezo-electric transducer, Non-conventional energy, Inverter, MOSFET, Piezo-tile, Step-up Transformer, Voltage.

## 1 INTRODUCTION

At present, electricity has become a lifeline for human population. Its demand is increasing day by day. Modern technology needs a huge amount of electrical power for its various operations. Electricity production is the single largest source of pollution in the whole world. At one hand, rising concern about the gap between demand and supply of electricity for masses has highlighted the exploration of alternate sources of energy and its sustainable use. On the other hand, human population all over the world and hence energy demand is increasing day by day linearly. Accordingly, it is an objective of the present invention to provide a method of electrical power generation from this ever increasing human population that does not negatively impact the environment.

This technology is based on a principle called the piezoelectric effect, in which certain materials have the ability to build up an electrical charge from having pressure and strain applied to them. Piezoelectricity refers to the ability of some materials to generate an electric potential in response to applied pressure. Harvesting of energy which means energy is already available, but is going to waste if not utilized

## 2 PROCEDURE FOR PAPER SUBMISSION

### 2.1 Study of Piezo Electric materials:

Piezoelectric ceramics belong to the group of ferroelectric materials. Ferroelectric materials are crystals which are polar without an electric field being applied. The piezoelectric effect is common in piezo ceramics like  $\text{PbTiO}_3$ ,  $\text{PbZrO}_3$ , PVDF and PZT. The main component of the project is the piezoelectric material. The proper choice of the piezo material is of prime importance. For this, an analysis on the 2 most commonly available piezoelectric material - PZT and PVDF, to determine the most suitable material was done. The criterion for selection was better output voltage for various pressures applied. In order to understand the output corresponding to the various forces applied, the V-I characteristics of each material namely, PZT and PVDF were plotted. For this the Piezo transducer material under test is placed on a Piezo force sensor.

The voltage from PZT is around 2 V where as that of PVDF is around 0.4V. We can thus conclude that better output is obtained from the PZT than the PVDF.

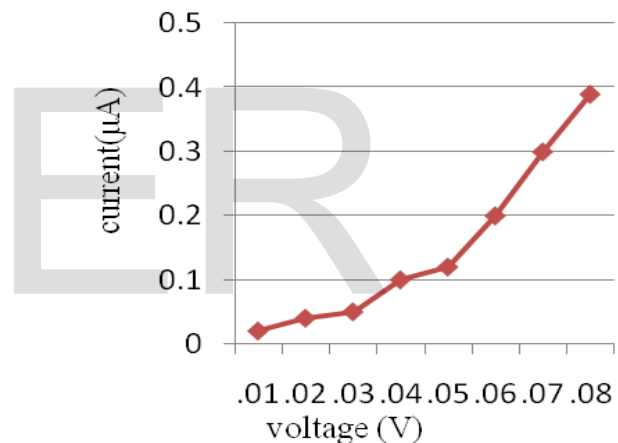


Fig 1: V-I graph of PVDF material

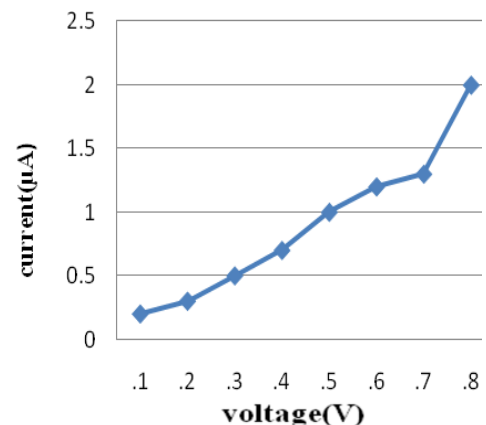
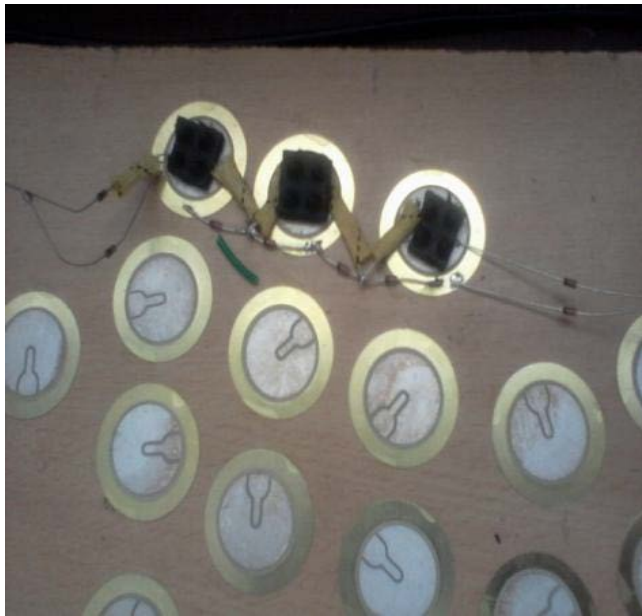


Fig 2: V-I graph of PZT

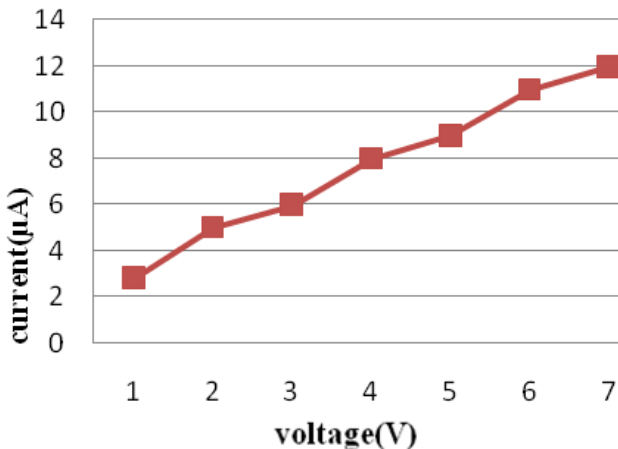
**2.2 Study of connections:**

Next to determine the kind of connection that gives appreciable voltage and current necessary, three PZT are connected in series.

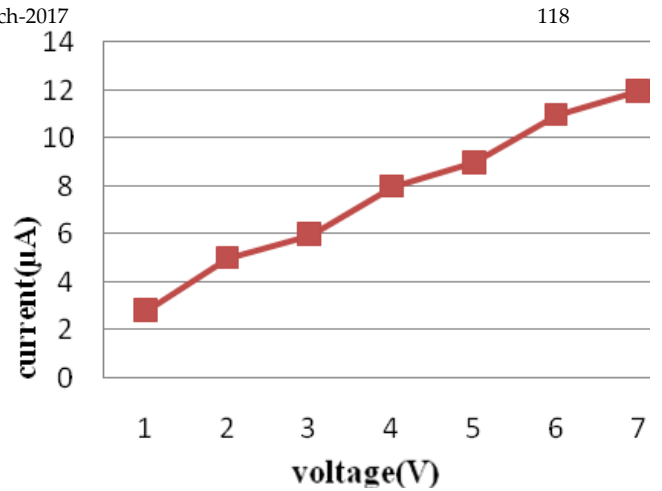


**Fig 3: PZT in series connection**

A force sensor and voltmeter is connected to this series combination. As varying forces are applied on this connection, corresponding voltages are noted. Also the voltage generated across the series connection and the current is measured. Similarly the connections are done for parallel and series-parallel connections are done and the graphs are as in figures 4 and 5.



**Fig 4: V-I graph of parallel and series connection**



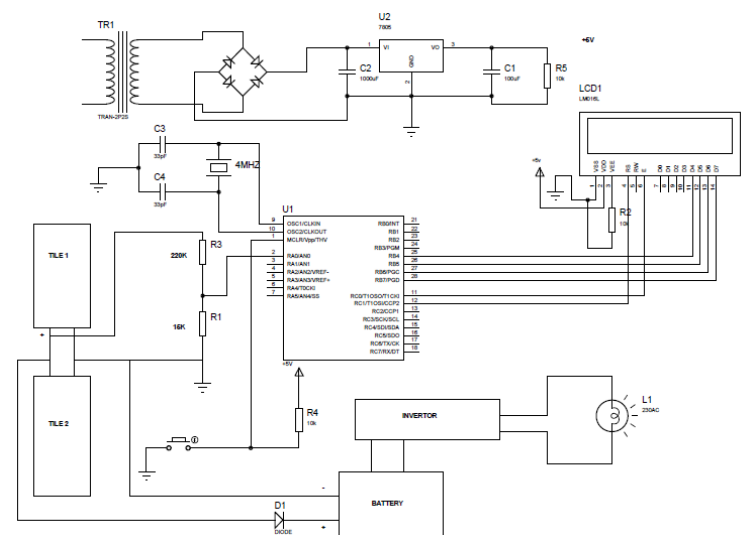
**Fig 5: V-I graph of parallel and series combination**

It can be seen from the graph that the voltage from a series connection is good but the current obtained is poor, whereas the current from a parallel connection is good but the voltage is poor. But this problem is rectified in a series-parallel connection where a good voltage as well as current can be obtained.

**2.3 Hardware Implementation :**

The hardware set up is as shown in figure 6. A tile made from piezo material is made. The voltage generated across a piezo tile is supplied to a battery for it to recharge and supply the dc loads. Voltage generated is also given to an inverter, from where it is supplied to all the ac loads. A LCD is interfaced to the tile using a PIC microcontroller to display the voltage generated across the piezo tile.

**2.4 Working:**



**Fig 6: Hardware setup**

The piezoelectric material converts the pressure applied to it into electrical energy. The source of pressure can be either from the weight of the moving vehicles or from the weight of the people walking over it. The output of the piezoelectric material is not a steady one. So a bridge circuit is used to convert this variable voltage into a linear one. Again an AC ripple filter is used to filter out any further fluctuations in the output. The output dc voltage is then stored in a rechargeable battery. As the power output from a single piezo-film was extremely low, combination of few Piezo films was investigated. Two possible connections were tested - parallel and series connections. The parallel connection did not show significant increase in the voltage output. With series connection, additional piezo-film results in increased of voltage output but not in linear proportion. So here a combination of both parallel and series connection is employed for producing 40V voltage output with high current density. From battery provisions are provided to connect dc load. An inverter is connected to battery to provide provision to connect AC load. The voltage produced across the tile can be seen in a LCD. For this purpose microcontroller PIC16F873A is used. The microcontroller uses a crystal oscillator for its operation. The output of the microcontroller is then given to the LCD which then displays the voltage levels.

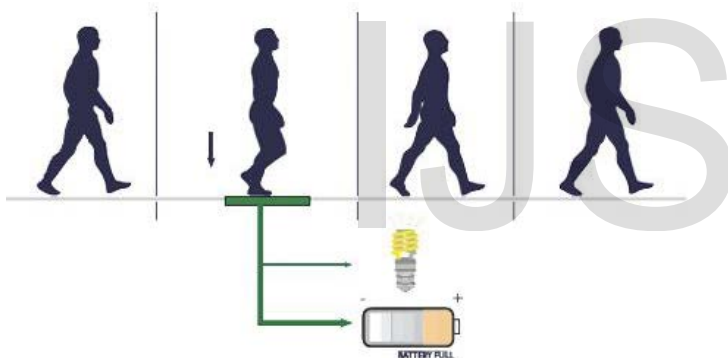


Fig 7: Schematic representation of the working model

The inverter used in this circuit uses the IC CD4047. It is used to convert the DC voltage stored in the battery to AC voltage. IC CD4047 produces two pulse trains phase shifted by 180°. These pulse trains are used to switch transistors configured in common emitter mode producing pulse trains of 12V, which is

capable of switching a MOSFET.

The sources of the two MOSFETs used in the inverter circuit are supplied with a 12V supply. When the MOSFETs are switched on by the outputs of the transistors, two output pulses of 12V are obtained. These pulses are connected to a step up transformer from whose high voltage side; we obtain the 220V AC supply.

### 3. VOLTAGE GENERATED:

When a force is applied on piezo material, a charge is generated across it. Thus, it can be assumed to be an ideal capacitor. Thus, all equations governing capacitors can be applied to it. In this project, on one tile, we connect 3 piezo in series. 10 such series connections are connected in parallel. Thus when 3 piezoelectric discs are connected in series, its equivalent capacitance becomes:

$$1/C_{eq} = 1/C_1 + 1/C_2 + 1/C_3 \quad (i)$$

We know,  $Q = C * V$  (ii)

So,  $C = Q/V$  (iii)

Hence,  $V_{eq} = V_1/Q + V_2/Q + V_3/Q$  (iv)

Thus,  $V_{eq} = V_1 + V_2 + V_3$  (v)

Hence, the net voltage generated in series connection is the sum of individual voltages generated across each piezoelectric disc. Output voltage from 1 piezo disc is 13V.

Thus,  $V_{eq} = 13 + 13 + 13$   
 $= 39V$

Thus the maximum voltage that can be generated across the piezo tile is around 39V.

### 4 ANALYSIS ON PIEZO TILE:

People whose weight varied from 40kg to 75 kg were made to walk on the piezo tile to test the voltage generating capacity of the Piezo tile. The relation between the weight of the person and power generated is plotted in figure 8. From the graph it can be seen that, maximum voltage is generated when maximum weight/force is applied. Thus, maximum voltage of 40V is generated across the tile when a weight of 75 Kg is applied on the tile.

- Shrimoyee Poddar is currently pursuing bachelors degree(B.Tech) program in electrical engineering in Maulana Abul Kalam Azad University of Technology(Formerly WBUT, India, PH-8981553556. E-mail:[shrimoyee95@gmail.com](mailto:shrimoyee95@gmail.com))
- Mohuya Dutta is currently pursuing bachelors degree (B.Tech) program in electrical engineering in Maulana Abul Kalam Azad University of Technology (Formerly WBUT), India, PH-9804328446.
- Debashree Chowdhury is currently pursuing bachelors degree(B.Tech) program in electrical engineering in Maulana Abul Kalam Azad University of Technology(Formerly WBUT), India, PH-8334009224
- Abhinaba Dey is currently pursuing bachelors degree(B.Tech)program in Electrical engineering in Maulana Abul Kalam Azad University of Technology(Formerly WBUT), India, PH-8276966882

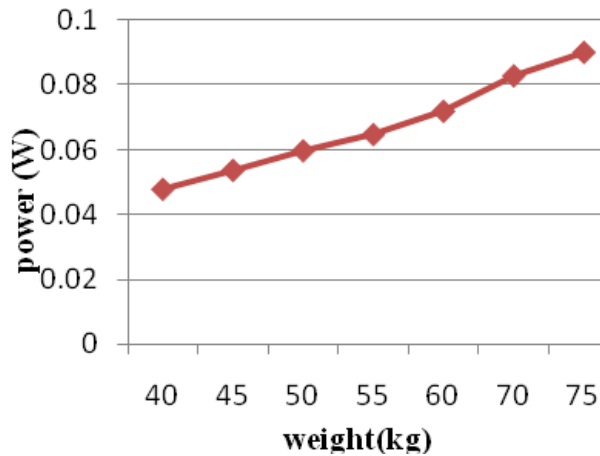


Fig 8: Weight V/s power graph of piezo tile

#### 4 CONCLUSION

A piezo tile capable of generating 40V has been devised. Comparison between various piezo electric material shows that PZT is superior in characteristics. Also, by comparison it was found that series- parallel combination connection is more suitable. The weight applied on the tile and corresponding voltage generated is studied and they are found to have linear relation. It is especially suited for implementation in crowded areas. This can be used in street lighting without use of long power lines. It can also be used as charging ports, lighting of pavement side buildings.

#### 5 FUTURE WORK AND RESULT

This footstep voltage generator using Piezo-electric sensor can be improved by employing a step-up transformer. As we can see, we are not getting enough voltage from a single circuit of foot step voltage generator.

Now, by our implementation we can generate much more voltage from our footsteps only. This is done here by connecting many foot step voltage generator circuits in series and at the output end if we use a step up transformer then we can produce huge amount of voltage than the voltage which is obtained in single circuit of foot step voltage generator.

This project is designed to use in public places like railway stations and also in schools, colleges, office areas, metro stations, airport, etc basically where many people passes daily. At such places, this instrument can be placed at the entry point to get huge amount of voltage. Exits in certain places can also be used for such purpose. This device will generate a voltage at every foot step.

It will be a huge source of non-conventional energy. Nowadays, Non-conventional energy is becoming must since only by this we can overcome the crisis that is faced in using conventional energy i.e, fossil fuels like coal, petroleum, natural gas, etc. Once these resources are depleted, it takes another decade for restoration and hence the crisis of energy is formed. Producing electricity requires 67% energy source from fossil fuels which creates a great crisis specially coal and petroleum. Thus is implementation may be helpful to meet this energy crisis.

#### 6 ACKNOWLEDGMENT

We, the authors of this project report, would take the opportunity to thank Mr. Debasis Maji, our project guide for supporting us constantly and giving us invaluable insights. His guidance, inspiration and constructive suggestions motivated us to achieve our goal and impetus to excel.

#### REFERENCES

- [1] Electronic devices and circuit theory by Robert L. Boylestead and Louis Nashlsky.
- [2] Knight, Jones, & Field, "College Physics" (2007).
- [3] How it works: Science & Technology (third Edition) volume 13 by Marshall Caven Dish.
- [4] Nilsson J Thorstensson, a ground reaction forces at different speeds of human walking and running. Act Physiological Scandinavica. Vol 136.
- [5] "Energy Harvesting" <http://www.scribd.com/footstep-power-generation-system.html> 3/7/2013